

25G PIN Photodetector with TIA ROSA

up to 25Gb/s, 1260-1620 nm



DATASHEET

[Return to the Webpage](#)



Features

- High performance InGaAs/InP photodetector
- Integrated with amplifier
- Support bit rate up to 25Gb/s
- Operating wavelength of 1260~1620nm
- LC receptacle coaxial package
- Wide temperature range:-40°C to 85°C.

Applications

- 25G Optical Networks
- 5G Wireless



The ROSA (Receiver Optical Sub-Assembly) is built on a proven transceiver fabrication platform, delivering low cost, high bandwidth, high coupling efficiency, and long-term stability. As a critical component in optical networks, it converts incoming optical signals into electrical signals. This ROSA variant is available with or without an integrated transimpedance amplifier (TIA), enabling high-fidelity analog output and making it particularly suitable for precision analog applications. The device sensitivity scales approximately with the photodetector's active area, while response speed is inversely proportional, reflecting a fundamental tradeoff between sensitivity and bandwidth; similarly, optical power handling increases with detector area due to thermal conductivity and power density limits. The bonding materials meet stringent low-outgassing requirements and are rated for operation up to 85 °C, while the mechanical package complies with Telcordia GR-1221 reliability standards and supports both PCB and panel mounting. . A matching evaluation PCB is available, featuring up to 8 GHz 3 dB analog bandwidth and SMA RF interfaces, with a single connector for single-ended output and dual connectors for differential outputs, enabling convenient testing and system integration.

Due to high sensitivity to electrostatic discharge (ESD), warranty coverage applies only to fully metal-encased modules and benchtop units with proper protection; other laser and photodetector versions are not covered and must be handled with extreme care.

Specifications

Parameter	Min	Typical	Max	Unit
Wavelength	1260		1620	nm
Supply Voltage	3.0	3.3	3.6	V
Supply Current	20	25	35	mA
Responsivity (1310nm, Pin=-20dBm)	0.3	0.38		A/W
Sensitivity (1310nm, ER=4dB)		-15	-14	dBm
Saturation Power	2			dBm
Optical Return Loss (1310nm)	26			dB
Storage Temperature	-40		+85	°C
Operating Temperature	-40		+85	°C
Relative Humidity	5		95	%
Supply Voltage	-0.5		4	V
Lead Soldering Temperature		360/5, 260/10		°C/s
Input Optical Power			2	mW

Legal notices: All product information is believed to be accurate and is subject to change without notice. Information contained herein shall legally bind Agiltron only if it is specifically incorporated into the terms and conditions of a sales agreement. Some specific combinations of options may not be available. The user assumes all risks and liability whatsoever in connection with the use of a product or its application.

Rev 04/08/26

[+1 781-935-1200](tel:+17819351200)

sales@agiltron.com

www.agiltron.com

25G PIN Photodetector with TIA ROSA

up to 25Gb/s, 1260-1620 nm



DATASHEET

Mechanical Dimensions (mm)

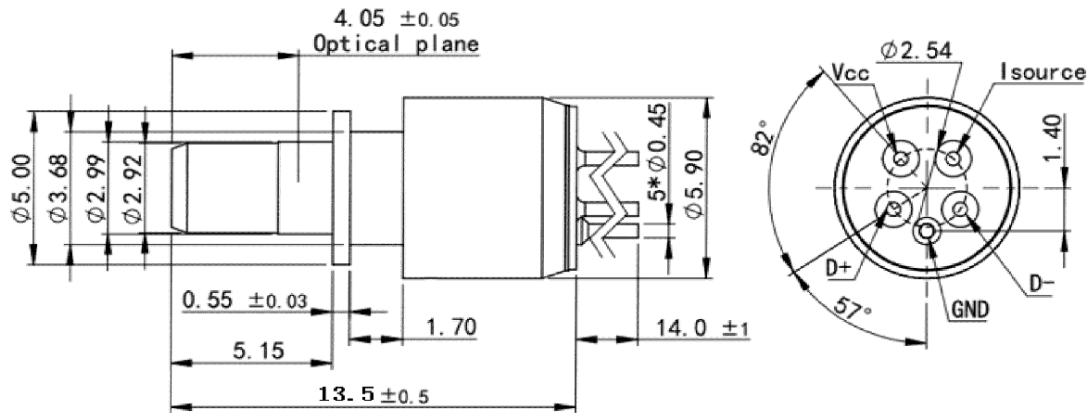

*Product dimensions may change without notice. This is sometimes required for non-standard specifications.

25G PIN Photodetector with TIA ROSA

up to 25Gb/s, 1260-1620 nm



DATASHEET

Ordering Information (Part Number)

	1	1	M	<input type="checkbox"/>	2	1	1
Prefix	Wavelength	Type	Bandwidth	PCB Driver	TIA	Package	Receptacle
ROSA-	1230-1620nm = 1 400-1000nm ^[1] = 2 850nm = 8	InGaAs PIN = 1 InGaAs APD = 2 Si PIN = 3	0.1 GHz (~100 μm) = 1 1.25 GHz(~30 μm) = 2 3 GHz(~30 μm) = 3 5 GHz (~20 μm) = 5 10 GHz (~10 μm) = 6 2.5 GHz = 7 12 GHz = 8 15 GHz = 9 25 GHz = M	None =N Single Output = 1 Differential =2	Non = 1 One Stage = 2 Two Stage = 3	Standard = 1 Special = 0	LC = 1 Special = 0

[1]. For Silicon only

[2]. For 850nm only

Application Notes