



Broadband NanoSpeed™ Variable Optical Attenuator (MMF version)

(Bidirectional)

(Protected by U.S. patent 7,403,677B1 and pending patents)

Product Description

The Nano-speed Premium Variable Fiber Optical Attenuator (NPOA) provides electrical control of optical power. This is achieved using a patent pending non-mechanical configuration and activated via a voltage electrical control signal. The solid-state optical crystal design eliminates mechanical movement and organic materials. The NP Series Variable Optical Attenuators are designed to meet the most demanding operation requirements of ultra-high reliability and fast response time with minimal mechanical footprint. Agiltron also offers customized electronic designs to meet special control requirements and applications. The NPOA is bidirectional. The NP Series VOA is available in either normally-transparent in which the light passing through without the applying a voltage or normally-opaque in which the light is blocked without the applying of a voltage. The attenuation level is related to the stage. The response speed is related to the attenuation level and driver power (repetition rate). Small attenuation can reach MHz response.

The NP Series VOA is mounted on a specially designed electronic driving PCB board with a 0-5V control input and having performance optimized for various repetition rate.

Performance Specifications

Broadband NVOA	Min	Typical	Max	Unit
Wavelength	1260		1625	nm
Insertion Loss ^[1]		1.2	1.5	dB
Polarization Dependent Loss		0.1	0.35	dB
Return Loss	45	50		dB
Attenuation Range	13			dB
Response Time (Rise, Fall)			300	ns
Repetition Rate ^[2]	DC	5	100	kHz
Resolution		Continuously		dB
Operating Optical Power			500	mW
Operating Temperature		-5 ~ 70		°C
Storage Temperature		-40 ~ 85		°C
Package Dimension		56 X8.2X5.95		mm

[1] Excluding connectors.

[2] 5kHz and 100kHz repeat rates are realized in the different drivers.

[3] Special circuit for narrow frequency range, maximum modulation depth is 5-10%

Features

- Solid state
- High Reliability
- High Speed
- Broadband
- Bidirectional
- Low Insertion Loss
- Compact

Applications

- Power Control
- Power Regulation
- Power Balance
- Instrumentation



Broadband NanoSpeed™ Fiber Optical Variable Attenuator (MMF version)

Mechanical Dimensions (mm)

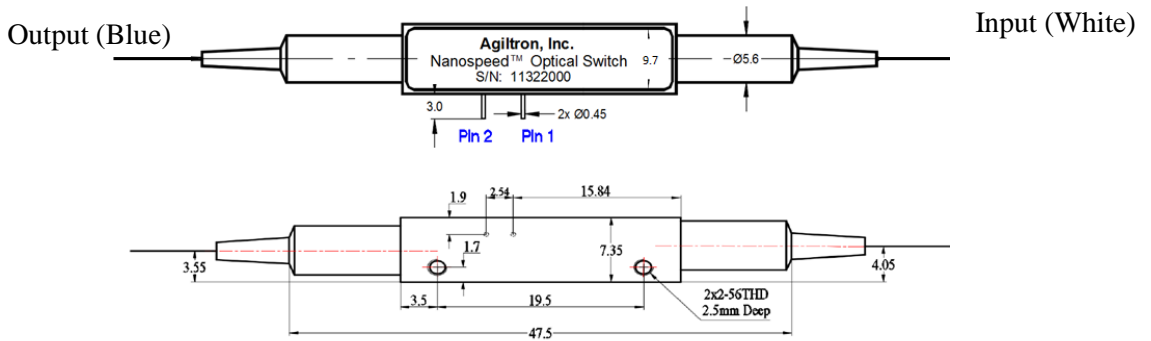

Normal Power VOA

*Product dimensions may change without notice. This is sometimes required for non-standard specifications.

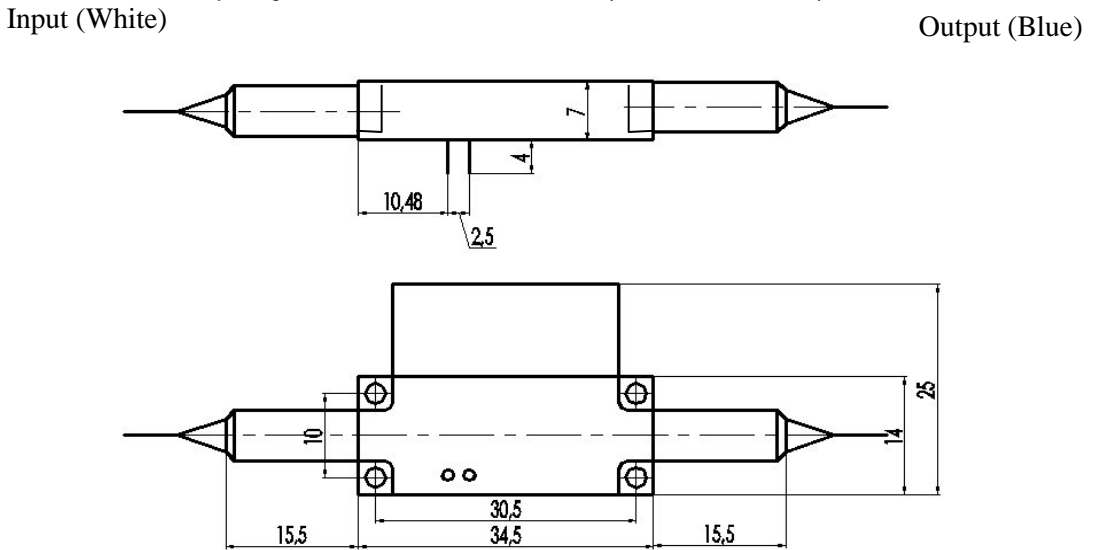

High Power VOA

Broadband NanoSpeed™ Fiber Optical Variable Attenuator (MMF version)

Typical Speed and Repetition Measurement

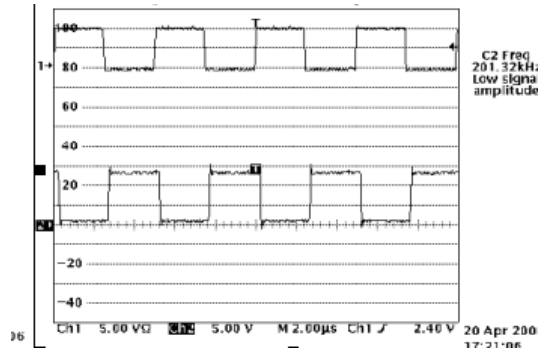
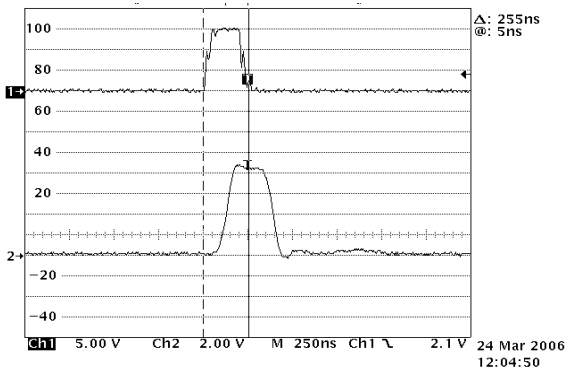

Driving Board Selection

Maximum Repetition Rate	Part Number (P/N)
5kHz	NVDR-111221112
20kHz	NVDR-113235112
100kHz	NVDR-112221112

Typical Attenuation versus Voltage

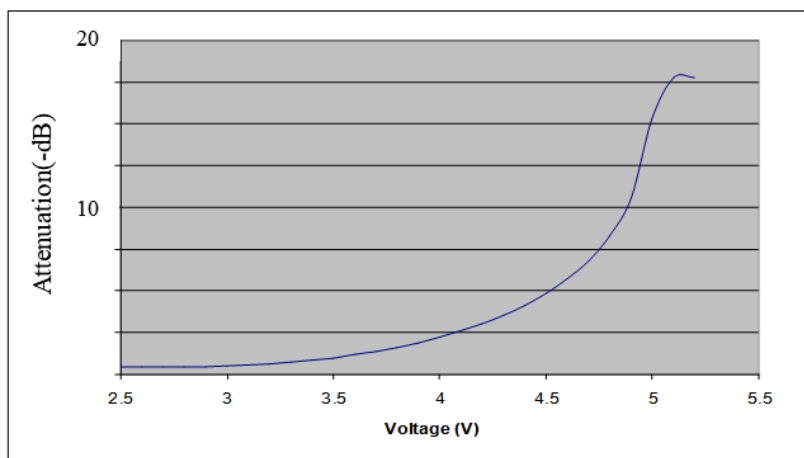

* Note: For customers that prefer to design their own driving circuit, they are responsible for the optical performance. For more technical information, please contact us.

Broadband NanoSpeed™ Variable Optical Attenuator

Specify wavelength dependent loss @10dB attenuation

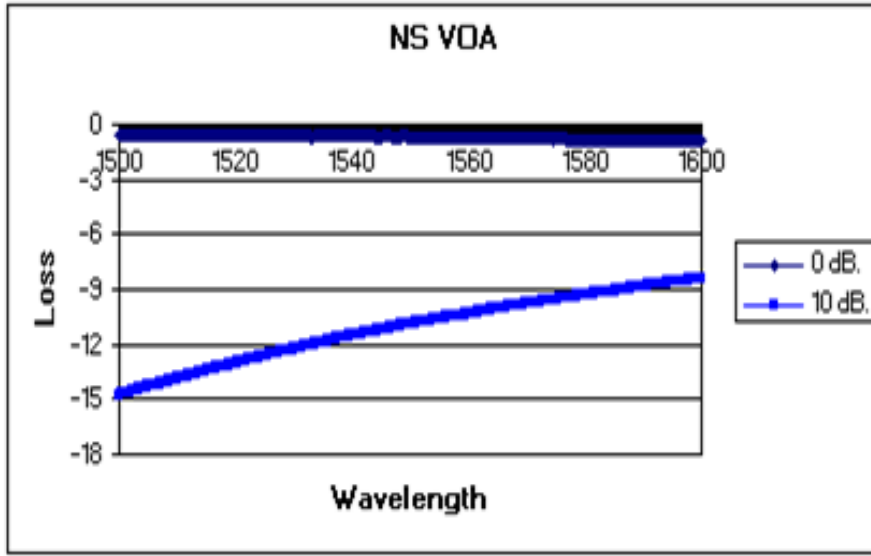

Ordering Information

Prefix	Type	Wavelength	State	Optical power	Fiber Type	Fiber Cover	Fiber Length	Connector
NMOA-	Regular slope=2	1260-1620nm=1 Special=0	Transparent = 1 Opaque = 2	500mW=8 2W CW=2 5W CW=5	50/125 =5 62.5/125 = 6 Special=0	Bare fiber = 1 900um loose tube=3 Special = 0	0.25m = 1 0.5m = 2 1.0 m = 3 Special = 0	None = 1 FC/PC = 2 FC/APC = 3 SC/PC = 4 SC/APC = 5 ST/PC = 6 LC = 7 Special = 0

NOTE:

“transparent” means no attenuation without applying a controlling voltage, the “opaque” means the highest attenuation without applying a controlling voltage.



Broadband NanoSpeed™ Variable Optical Attenuator

Q&A

Q: Does NS device drift over time and temperature?

A: NS devices are based on electro-optical crystal materials that can be influenced to a certain range by the environmental variations. The insertion loss of the device is only affected by the thermal expansion induced miss-alignment. For extended temperature operation, we offer special packaging to -40 -100 °C. The extinction or cross-talk value is affected by many EO material characters, including temperature-dependent birefringence, V_p , temperature gradient, optical power, at resonance points (electronic). However, the devices are designed to meet the minimum extinction/cross-talk stated on the spec sheets. It is important to avoid a temperature gradient along the device length.

Q: What is the actual applying voltage on the device?

A: 100 to 400V depending on the version.

Q: How does the device work?

A: NS devices are not based on Mach-Zander Interference, rather birefringence crystal's nature beam displacement, in which the crystal creates two different paths for beams with different polarization orientations.

Q: What is the limitation for faster operation?

A: NS devices have been tested to have an optical response of about 300 ps. However, practical implementation limits the response speeds. It is possible to achieve a much faster response when operated at partial extinction value. We also offer resonance devices over 20MHz with low electrical power consumption.

Operation Manual

1. Connect a control signal to the SMA connector on the PCB
2. Attach the accompanied power supply (typically a wall-pluggable unit).
3. The device should then function properly.

Note: Do not alter device factory settings.