

LightBend™ High Power Fiber Optical 2x2 Switch Bidirectional

(Protected by U.S. patent 6823102 and pending patents)



DATASHEET

BUY NOW



The LB series Full 2x2 High Power fiber optic switch is a polarization-maintaining fiber switch that connects optical channels by directing or blocking an incoming optical signal into the output fiber. This is achieved using a patent pending optomechanical configuration via an electrical control signal. A latching version preserves the selected optical path after the drive signal has been removed, while the non-latching version defaults to either the open or close state when power is removed. The switch has integrated electrical position sensors. The new material-based advanced design significantly reduces moving part position sensitivity, offering unprecedented high stability and an unmatched low cost. An electronic driver is available for this series of switches. The switch is bidirectional.

Features

- Low Optical Distortions
- High Isolation
- High Reliability
- Fail-Safe Latching
- Epoxy-Free Optical Path

Applications

- Fault Protection
- Channel Add/Drop
- Channel Switching
- Instrumentation

Specifications

Parameter	Min	Typical	Max	Unit
Operation Wavelength	850, 1310, 1550			nm
Insertion Loss		0.6	1.1	dB
Wavelength Dependent Loss			0.25	dB
Temperature Dependent Loss			± 0.15	dB
Polarization Dependent Loss			0.1	dB
Return Loss	50			dB
Cross Talk	50			dB
Switching Time		3	10	ms
Repeatability			± 0.02	dB
Durability	10 ⁷			cycle
Operating Voltage	4.5	5	6	VDC
Operating Current (Latching/Non-Latching)		30	60	mA
Switching Type	Latching / Non Latching			
Operating Temperature	-5		70	°C
Storage Temperature	-40		85	°C
Optical Power Handling		5	10	W

Notes:

- [1]. Exclude connectors
- [2]. Within operating temperature and SOP
- [3] Light source CPR<14 dB.
- [4] Continuous operation, for Pulse operation call.

Warning: This device must use the reference circuit to driver otherwise it is unstable

Legal notices: All product information is believed to be accurate and is subject to change without notice. Information contained herein shall legally bind Agiltron only if it is specifically incorporated into the terms and conditions of a sales agreement. Some specific combinations of options may not be available. The user assumes all risks and liability whatsoever in connection with the use of a product or its application.

Rev 03/04/24

© Photonwares Corporation

P +1 781-935-1200

E sales@photonwares.com

W www.agiltron.com

Information contained herein is deemed to be reliable and accurate as of the issue date. Photonwares reserves the right to change the design or specifications at any time without notice. Agiltron is a registered trademark of Photonwares Corporation in the U.S. and other countries.

LightBend™ High Power Fiber Optical 2x2 Switch Bidirectional



(Protected by U.S. patent 6823102 and pending patents)

DATASHEET

Mechanical Dimensions (mm)

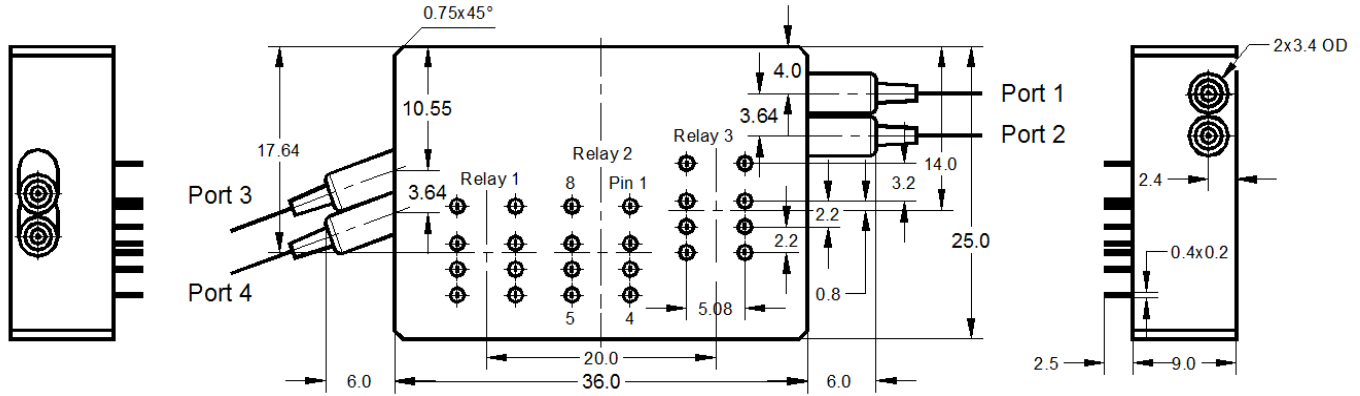

*Product dimensions may change without notice. This is sometimes required for non-standard specifications.

Electrical Driving Requirements

The load is a resistive coil which is activated by applying 5V (draw ~ 40mA). However, the current flow direction must be correct otherwise it will cancel the permanent magnet inside causing instability. We strongly recommend to use the reference circuit to avoid major issues. We offer pushbutton elevation driver for verifications or convenient income inspection.

Latching Type

Application Note: Applying a constant driving voltage increases stability. The switches can also be driven by a pulse mode using Agiltron recommended circuit for energy saving.

Optical Path	Relay	Electrical Drive		Status Sensor			
		Pin 1	Pin 8	Pin 2-3	Pin 3-4	Pin 5-6	Pin 6-7
Port 1 → Port 3 Port 2 → Port 4	Relay 1, 3	0	5V	Close	Open	Open	Close
	Relay 2	5V	0	Open	Close	Close	Open
Port 1 → Port 4 Port 2 → Port 3	Relay 1, 3	5V	0	Open	Close	Close	Open
	Relay 2	0	5V	Close	Open	Open	Close

Non-Latching Type

Optical Path	Relay	Electrical Drive		Status Sensor			
		Pin 1	Pin 8	Pin 2-3	Pin 3-4	Pin 5-6	Pin 6-7
Port 1 → Port 3 Port 2 → Port 4	Relay 1, 3	No Power		Close	Open	Open	Close
	Relay 2	5V	0	Open	Close	Close	Open
Port 1 → Port 4 Port 2 → Port 3	Relay 1, 3	5V	0	Open	Close	Close	Open
	Relay 2	No Power		Close	Open	Open	Close

Functional Diagram

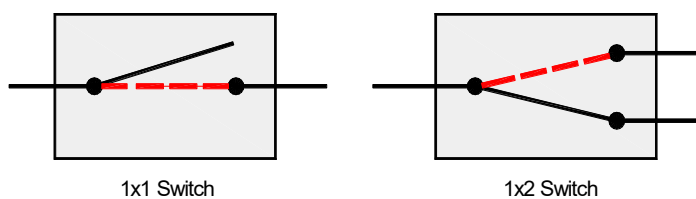

LightBend™ High Power Fiber Optical 2x2 Switch Bidirectional

(Protected by U.S. patent 6823102 and pending patents)



DATASHEET

Functional Diagram

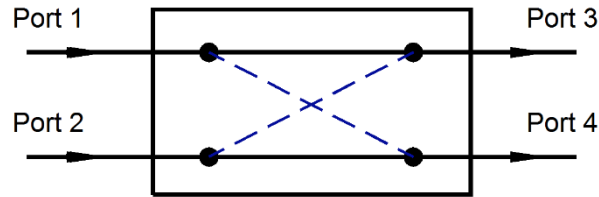

LB Full 2x2 High Power Switch

Ordering Information (Part Number)

Prefix	Type	Wavelength	Switch	Power	Fiber Type	Fiber Cover	Fiber Length	Connector ^{[4][5]}
LBSH ^[1]	2x2 = 22	1060 = 1	Latching = 1	5W = 4	SMF-28 = 1	Bare Fiber = 1	0.25m = 1	None = 1
LBMH ^[2]	Special = 00	1310 = 3	Non-latching = 2	10W = 5	MM 50/125 = 5	900um Tube = 3	0.5m = 2	FC/PC = 2
LBPH ^[3]		1410 = 4	Special = 0	Special = 0	MM 62.5/125 = 6	Special = 0	1.0m = 3	FC/APC = 3
		1550 = 5			PM1550 = B		Special = 0	SC/PC = 4
		650 = 6			PM1310 = D			SC/APC = 5
		780 = 7			PM980 = E			ST/PC = 6
		850 = 8			PM850 = F			LC/PC = 7
		Special = 0			PM1950 = G			Duplex LC/PC = 8
					PM1060 = H			LC/APC = A
					Special = 0			LC/UPC = U
								Special = 0

[1]. **LBSH**: LightBend **SM** High Power Switch

[2]. **LBMH**: LightBend **MM** High Power Switch

[3]. **LBPH**: LightBend **PM** High Power Switch

[4]. Regular connectors cannot handle high power. Agiltron produces high-power connectors; please call.

[5]. The connector cannot be installed directly onto bare fiber, as it is prone to damage during shipping. However, the connector can be assembled on bare fiber if a 3 cm protective loose tube is added for reinforcement. The customer can remove this protective tube after testing. The optical power handling of a standard connector is less than 0.5 W for SM28 fiber and decreases further with smaller core fibers.

Fiber Core Alignment

Note that the minimum attenuation for these devices depends on excellent core-to-core alignment when the connectors are mated. This is crucial for shorter wavelengths with smaller fiber core diameters that can increase the loss of many decibels above the specification if they are not perfectly aligned. Different vendors' connectors may not mate well with each other, especially for angled APC.

Fiber Cleanliness

Fibers with smaller core diameters (<5 μm) must be kept extremely clean, contamination at fiber-fiber interfaces, combined with the high optical power density, can lead to significant optical damage. This type of damage usually requires re-polishing or replacement of the connector.

Maximum Optical Input Power

Due to their small fiber core diameters for short wavelength and high photon energies, the damage thresholds for device is substantially reduced than the common 1550nm fiber. To avoid damage to the exposed fiber end faces and internal components, the optical input power should never exceed 20 mW for wavelengths shorter 650nm. We produce a special version to increase the how handling by expanding the core side at the fiber ends.

LightBend™ High Power Fiber Optical 2x2 Switch Bidirectional

(Protected by U.S. patent 6823102 and pending patents)



DATASHEET

Driver Reference Design

