

# KD\*P Pockels Cell

## 9mm aperture, 200nm to 1600nm



DATASHEET

[Return to the Webpage](#)



### Features

- High Extinction Ratio
- Low Insertion Loss
- High Damage Threshold
- Low Capacitance
- Low Current Leakage
- Low Cost

### Applications

- Industrial Laser System
- Medical Laser System
- Aesthetic Laser System
- Military Laser System

KD\*P (Potassium Dideuterium Phosphate) is the most widely used material for electro-optical applications due to its excellent E-O properties. An electro-optic material such as KD\*P can alter the polarization state of light passing through it, when an applied voltage induces birefringence change in the crystal.

For amplitude modulation, polarized light is essential because the modulation process relies on controlling the intensity of light based on its polarization state. By incorporating input and output polarizers, the extinction ratio (ER) of the device is significantly improved.

### Specifications

Parameter	Min	Typical	Max	Unit
Chemical Formula	KD <sub>2</sub> PO <sub>4</sub>			
Transparency Range	200		1600	nm
Insertion Loss		< 2		%
Collimation		< 0.5		°
Wave front distortion (@633nm)		λ/6		
Clear Aperture		∅ 9		mm
Coatings	AR@1064nm(R<0.2%)			
Nonlinear Coefficients (d36)		0.40		pm/V
Refractive Index (1064nm)	No=1.4948, Ne=1.4554			
E-O Coefficients	r41=8.8pm/V, r63=25pm/V			
Longitudinal Half-wave Voltage	Vn=2.98KV (546nm)			
Quarter-wave voltage		~ 3400		V
Absorptance		0.006		1/cm
Optical Damage Threshold	> 1GW/ cm <sup>2</sup> 10ns 10Hz at 1064nm			
Extinction Ratio		> 30		dB
Size		∅ 25.4x39		mm
Voltage Extinction Ratio	>2000:1 (CP) >1500:1 (PP)			
Capacitance		< 6		pF
Scratch/Dig		20/10		

\* Sellmeier equations of KD\*P:(λ in um):  
 $n_o^2 = 1.9575544 + 0.2901391\lambda^2 / (\lambda^2 - 0.0281399) - 0.02824391\lambda^2 + 0.004977826\lambda^2$   
 $n_e^2 = 1.5005779 + 0.6276034\lambda^2 / (\lambda^2 - 0.0131558) - 0.01054063\lambda^2 + 0.002243821\lambda^2$

**Note:** The specifications provided are for general applications with a cost-effective approach. If you need to narrow or expand the tolerance, coverage, limit, or qualifications, please [click this link](#):

**Warning:** Do not use it, if you are not well trained. Do not clean the optical surfaces. Do not solder on crystals causing cracks. High voltage on the electrodes is extremely dangerous.

**Legal notices:** All product information is believed to be accurate and is subject to change without notice. Information contained herein shall legally bind Agiltron only if it is specifically incorporated into the terms and conditions of a sales agreement. Some specific combinations of options may not be available. The user assumes all risks and liability whatsoever in connection with the use of a product or its application.

Rev 03/07/25

© Photonwares Corporation

[+1 781-935-1200](tel:+17819351200)

[sales@photonwares.com](mailto:sales@photonwares.com)

[www.agiltron.com](http://www.agiltron.com)

Information contained herein is deemed to be reliable and accurate as of the issue date. Photonwares reserves the right to change the design or specifications at any time without notice. Agiltron is a registered trademark of Photonwares Corporation in the U.S. and other countries.

# KD\*P Pockels Cell

9mm aperture, 200nm to 1600nm



## DATASHEET

### Mechanical Dimensions (mm)

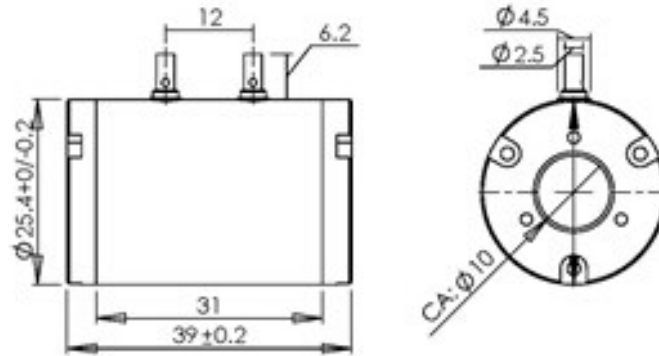

\*Product dimensions may change without notice. This is sometimes required for non-standard specifications.

### Ordering Information (Part Number)

Prefix	Type	Wavelength	Aperture		
PCDK-		430~700 nm = 0550 700~1000 nm = 0850 1064 nm = 1064	1	1	1