

# RF Over Fiber Analog/Digital Link 20GHz

10MHz to 20GHz, SM28 Fiber, Multimode 50/125 Fiber



DATASHEET

[Return to the Webpage](#)



## Features

- Up to 20GHz
- SM28 Fiber
- Low Loss
- Low Cost
- Stable

## Applications

- GSM Repeater
- CDMA Repeater
- WCDMA Repeater
- PHS Repeater
- Digital TV Repeater
- Broadcast Repeater



The RFOF is designed to form an RF link between two points using fiber optical cables. It features immunity to interferences, high bandwidth, low signal loss over long distances, low signal distortion, low power consumption, high reliability, and is easy to implement. It converts an input RF electrical signal into an optical signal via an electro-optical modulator coupled with a DFB laser (transmitter) and re-converts the optical signal back into the RF signal at the other end of the fiber link via a high linearity photodiode integrated with low noise amplifier (receiver). The transmitter and receiver pair form a transceiver that provides a transparent data transmission channel. They are available in wavelengths 1550nm C-band, providing a versatile wavelength division multiplexing (WDM) capability. For example, bidirectional RF communication can be established with a single fiber link using two different wavelength transceivers and matching WDM cable adaptors. Another example is that three channels can be transmitted through a single fiber link by combining three transceivers of different wavelengths with our WDM cable adaptors. The module is packaged in a rack mount box or ruggedized outdoor aluminum case. Temperature compensation is built into the transmitter.

The RFOF modules are suitable for telecommunications, satellites, radio telescopes, distribution antennas, broadcasting audio and video, and timing synchronization. For example, point-to-point antennas can be connected from several meters to many kilometers away from the control room by fiber cables; Base stations can be connected through fiber to remote sector antennas; Satellite antennas can be connected through fiber cable to remote sites by RF over Fiber solutions.

## Specifications

Parameter	Min	Typical	Max	Unit
Optical Wavelength	1520		1580	nm
Optical Output Power		3		mW
Optical Input Power	-16		-6	dBm
RF Frequency Range	0.01		20	GHz
Gain Flatness (p-p)			± 3	dB
RF Output Power	-30		-10	dBm
Input RF Return Loss		18		dB
RF Input Power			-10	dBm
Spurious Free Dynamic Range	100			dBm/H <sup>2/3</sup>
Noise Floor			-120	dBm/Hz
Transmit Gain Control (AGC)				
Receive Gain Control (AGC)				
Link Gain	0	5		dB
CNR	35			dB
Fiber Type		SM28		
Fiber Connector Type		SC/APC		
RF Impedance		50		Ω
RF Connector	GPPO Male to 2.92mm Female			
Power Consumption	3			W
Weight	0.5			kg
Operating Temperature	-20		50	°C
Storage Temperature	-45		85	°C

**Note:** The specifications provided are for general applications with a cost-effective approach. If you need to narrow or expand the tolerance, coverage, limit, or qualifications, please [click this link](#):

**Legal notices:** All product information is believed to be accurate and is subject to change without notice. Information contained herein shall legally bind Agiltron only if it is specifically incorporated into the terms and conditions of a sales agreement. Some specific combinations of options may not be available. The user assumes all risks and liability whatsoever in connection with the use of a product or its application.

Rev 04/02/26

[+1 781-935-1200](tel:+17819351200)

[sales@agiltron.com](mailto:sales@agiltron.com)

[www.agiltron.com](http://www.agiltron.com)

# RF Over Fiber Analog/Digital Link 20GHz

10MHz to 20GHz, SM28 Fiber, Multimode 50/125 Fiber



## DATASHEET

### Typical Response

■ S11

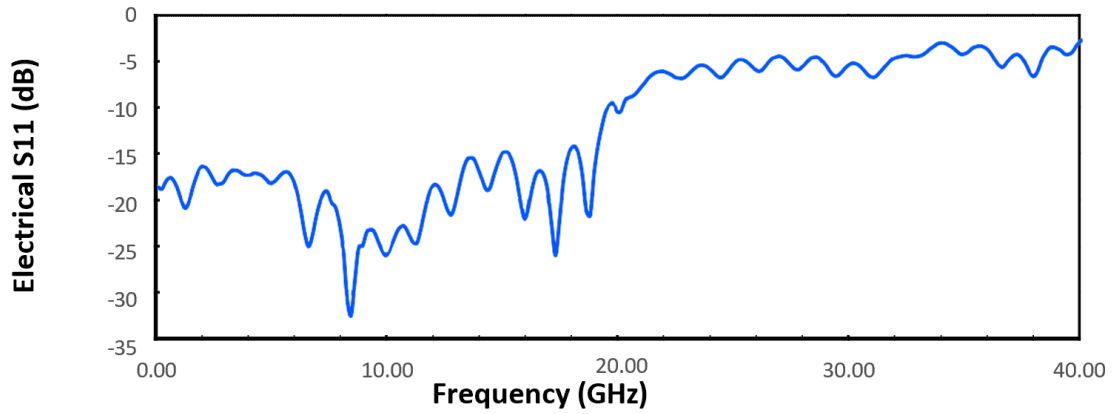

■ S21

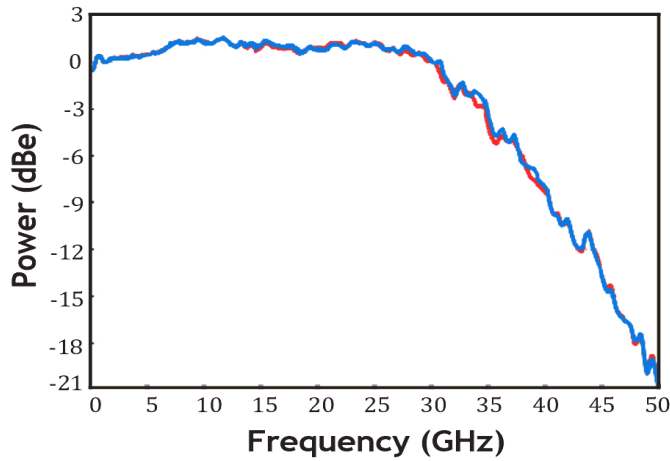

# RF Over Fiber Analog/Digital Link 20GHz

10MHz to 20GHz, SM28 Fiber, Multimode 50/125 Fiber



## DATASHEET

### Dimensions Module (Unit: mm)

#### Transmitter

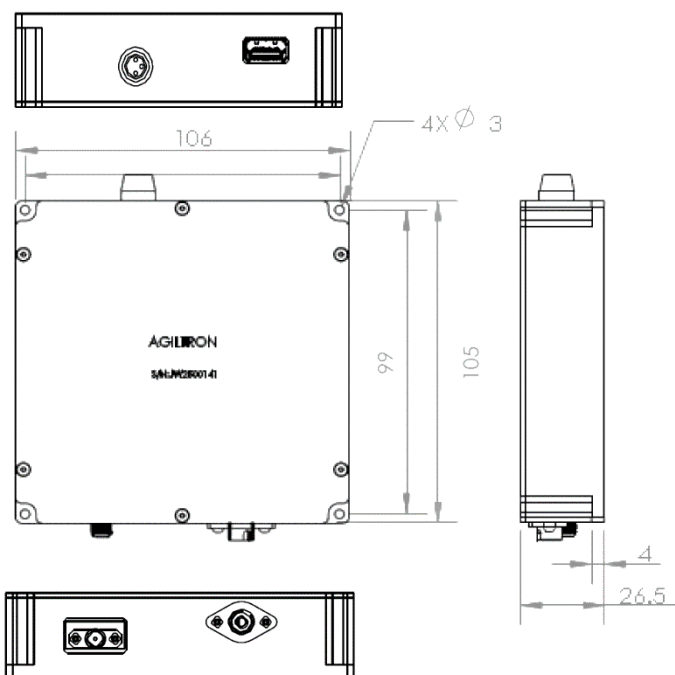

#### Receiver

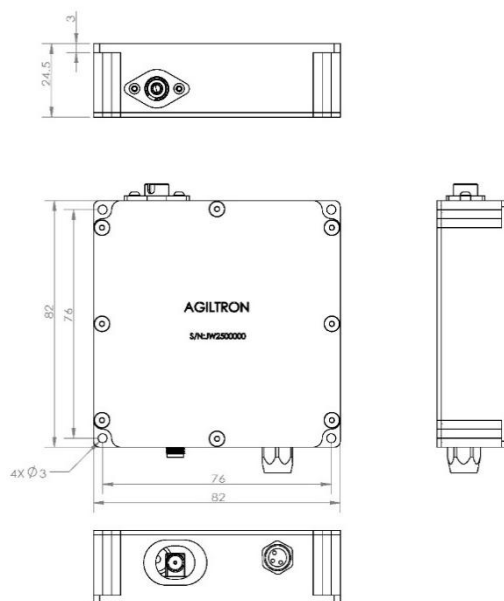

\*Product dimensions may change without notice. This is sometimes required for non-standard specifications.

### Ordering Information (Part Number)

Prefix	RF Frequency	Wavelength	TX/RX	Package	Bidirectional <sup>[1]</sup>	Fiber Connector <sup>[2]</sup>
RFOF-	20GHz SM = 20G 20GHz MM = 20M	1550 nm = 1 1560 nm = 2 Special = 0	Receiver = 1 Transmitter = 2 Pair = 3	Module = 1 Rack = 2 Special = 0	None = 1 Yes = 2 Special = 0	FC/APC = 2 FC/UPC = 3 SC/APC = 4 SC/UPC = 5 LC/APC = A LC/UPC = U Special = 0

#### Note:

- [1]. Bidirectional means two-way communications via a single fiber link. The price is double since it comprises two pairs of transceivers and receivers with WDM (different wavelength) or circulator (same wavelength) cable jumpers.
- [2]. The connector cannot be installed directly onto bare fiber, as it is prone to damage during shipping. However, the connector can be assembled on bare fiber if a 3 cm protective loose tube is added for reinforcement. The customer can remove this protective tube after testing. The optical power handling of a standard connector is less than 0.5 W for SM28 fiber and decreases further with smaller core fibers.

Red marked -- Special order

# RF Over Fiber Analog/Digital Link 20GHz

10MHz to 20GHz, SM28 Fiber, Multimode 50/125 Fiber



## DATASHEET

### Application Example 1 – Bidirectional RF Link via a Single Fiber

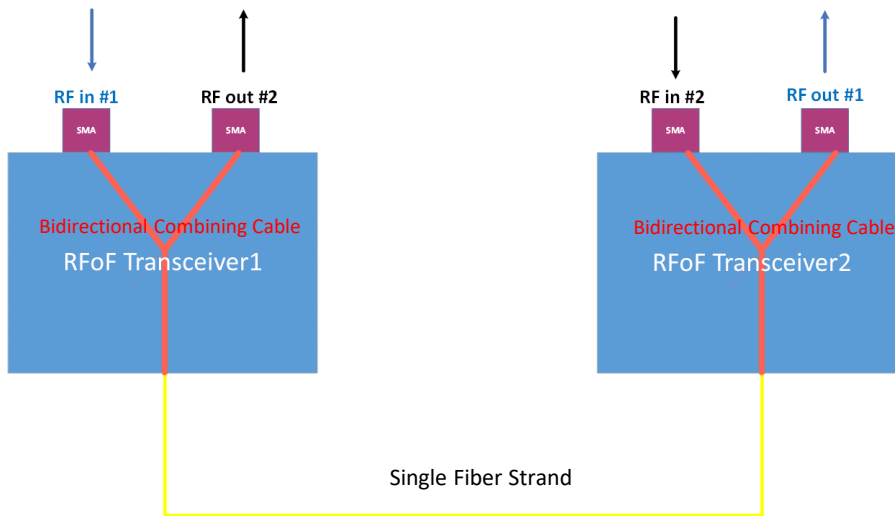

Bidirectional Combining Cable is based on fiber circulator \$650 ea

### Application Example – Satellite RF over Fiber Link

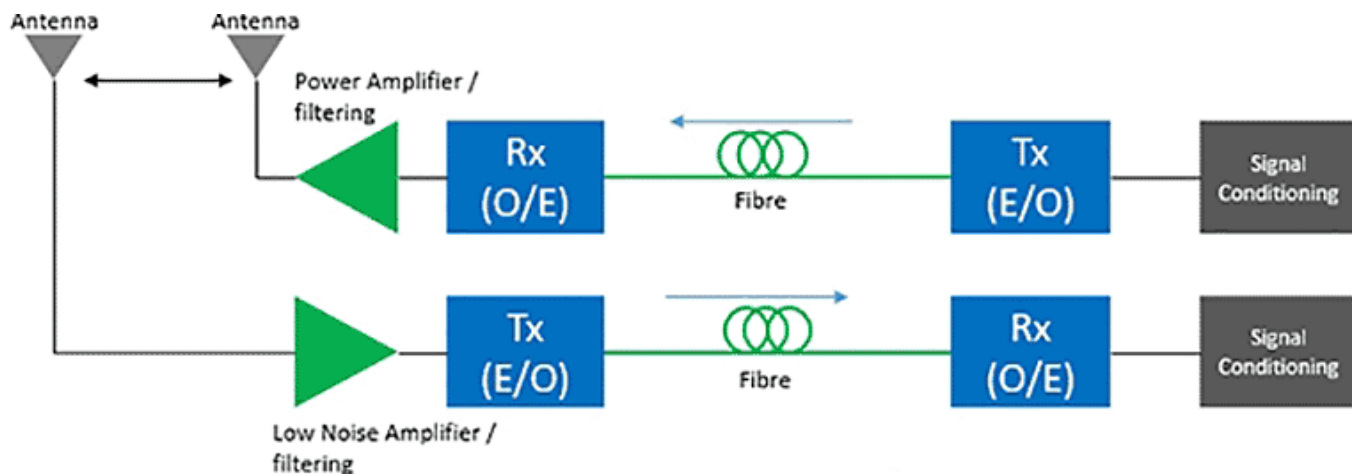

# RF Over Fiber Analog/Digital Link 20GHz

10MHz to 20GHz, SM28 Fiber, Multimode 50/125 Fiber



DATASHEET

## Function Diagram

### Transmitter

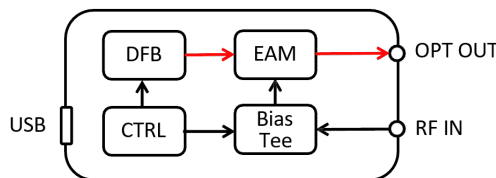

### Receivers

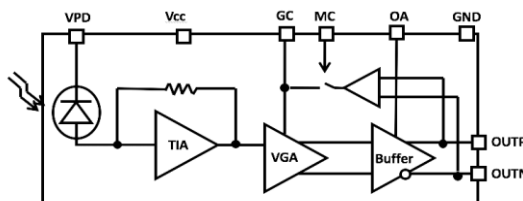

## Operation Instructions

1. Connect the optical fiber input port on the receiver to the signal source.
2. Connect the RF output port on the receiver to the RF input port of the transmitter.
3. Connect the RF output port of the transmitter to the readout instrument.
4. Plug in the provided power supply to power the device. The LED will turn on (CW for the receiver, blinking for the transmitter).
5. The unit will operate with the performance specified in the test report.
6. If the device does not function as expected, contact us via the sales email. **Do not open the enclosure — doing so will invalidate the one-year warranty.**

## Laser Safety

This product meets the appropriate standard in Title 21 of the Code of Federal Regulations (CFR). FDA/CDRH Class 1M laser product. This device has been classified with the FDA/CDRH under accession number 0220191. All versions of this laser are Class 1M laser products, tested according to IEC 60825-1:2007 / EN 60825-1:2007. An additional warning for Class 1M laser products. For diverging beams, this warning shall state that viewing the laser output with certain optical instruments (for example eye loupes, magnifiers, and microscopes) within a distance of 100 mm may pose an eye hazard. For collimated beams, this warning shall state that viewing the laser output with certain instruments designed for use at a distance (for example telescopes and binoculars) may pose an eye hazard.

Wavelength = 1.3/1.5  $\mu\text{m}$ .

Maximum power = 30 mW.

