

# Lithium Niobate Fiber Optical Modulator Bias Controller



(high extinction, little temperature dependence)

DATASHEET

[Return to the Webpage](#)



The LNBC series bias controllers provide salient performance enhancements. They enable the modulator's operation at the highest extinction ratio and independent of environmental changes. This is achieved by injecting a low-frequency, low-amplitude dither signal together with two built-in photodetectors to form a feedback bias control to maintain optimized performance and reduce temperature dependence. The bias is applied via an integrated micron heater.

The LNBC is designed to be used with thin film lithium niobate modulators with integrated detectors and heater.

## Features

- Increased Modulator Extinction Ratio
- Reduced Temperature Influence
- Minimum Dither Perturbation

## Applications

- Radar
- RoF
- Laboratory Uses
- Concept Proving
- Instrumentation

## Specifications

Parameter	Min	Typical	Max	Unit
Control Accuracy	1			degree
Extinction Ratio	27		50	dB
Dither Amplitude (%Vp)	0.2		2	%
Stabilization Time	4	10	50	s
Electrical Power Voltage	± 11.5		± 12.5	V
Output Voltage	0		10	V
Output Voltage Precision	0.04		0.1	mV
Output Current			10	mA
Dither Frequency		1		kHz
RF Input Power			30	dBm
Storage Temperature	-45		85	°C

**Note:** The specifications provided are for general applications with a cost-effective approach. If you need to narrow or expand the tolerance, coverage, limit, or qualifications, please [click this link](#):

**Legal notices:** All product information is believed to be accurate and is subject to change without notice. Information contained herein shall legally bind Agiltron only if it is specifically incorporated into the terms and conditions of a sales agreement. Some specific combinations of options may not be available. The user assumes all risks and liability whatsoever in connection with the use of a product or its application.

Rev 02/03/25

# Lithium Niobate Fiber Optical Modulator Bias Controller



(high extinction, little temperature dependence)

## DATASHEET

### Dimensions (mm)

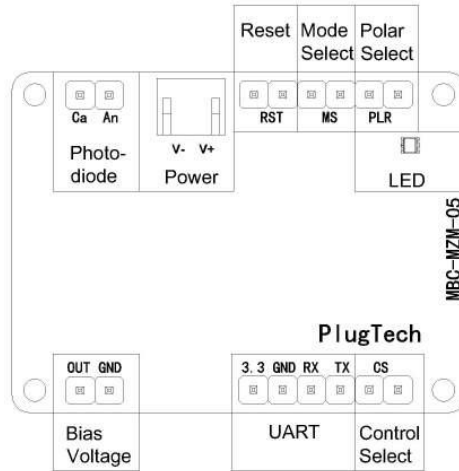

\*Product dimensions may change without notice. This is sometimes required for non-standard specifications.

### Electrical Connection

Group	Operation	Explanation
Photodiode <sup>1</sup>	PD: Connect MZM photodiode's Cathode	Provide photocurrent feedback
	GND: Connect MZM photodiode's Anode	
Power	Power source for bias controller	V-: connects the negative electrode
		V+: connects the positive electrode
		Middle probe: connects the ground electrode
Reset	Insert jumper and pull out after 1 second	Reset the controller
Mode Select	Insert or pull out the jumper	no jumper: Null mode; with jumper: Quad mode
Polar Select <sup>2</sup>	Insert or pull out the jumper	no jumper: Positive Polar; with jumper: Negative Polar
Bias Voltage	Connect with the MZM bias voltage port	OUT and GND provide bias voltages for modulator
LED	Green light constantly on	Working under stable state
	Green light blinking every 0.2s	Processing data and searching for controlling point
	Green light blinking every 1s	Input optical power is too weak
	Red light blinking every 3s	Input optical power is too strong
	Red light constantly on	Working under PauseControl mode or Manual mode
UART	Operate controller via UART	3.3: 3.3V reference voltage
		GND: Ground
		RX: Receive of controller
		TX: Transmit of controller
Control Select	Insert or pull out the jumper	no jumper: jumper control;with jumper:UART control

### Ordering Information (Part Number)

	<input type="checkbox"/>	1	1	1	1	1	1	<input type="checkbox"/>	1	
<b>Prefix</b>	<b>Configuration</b>							<b>Power Supply</b>		
<b>LNBC-</b>	Amplitude = 1 Phase = 2							No = 1 Yes = 2		